

oops!

WINTER 2025

SPRING 2026

Sheerline

Sunnyland Chapter of the Antique and Classic Boat Society



**Sunnyland
Antique & Classic
Boat Festival**
– Page 11

**Bill Hancock's
What is a
Valve Job**
– Page 20

***Cruising with the
Antique Outboard
Motor Club***
– Page 26

**SCAMPY
A Happenin'
Place**
– Page 28



Sheerline

Sunnyland Chapter of the Antique and Classic Boat Society



Sunnyland
Antique & Classic
Boat Festival
– Page 11

Bill Hancock's
What is a
Valve Job
– Page 20

*Cruising with the
Antique Outboard
Motor Club*
– Page 26

SCAMPY
A Happenin'
Place
– Page 28





**Your Key to the
Carefree Boating Lifestyle.**

Fully automatic boat covers remote
controlled from fab or phone app.



Live Life Better with the Touch of a Button.

- Raise and lower your Touchless Boat Cover® in seconds.
- Automatically controlled by remote, phone, or smart device.
- Custom covers up to 70 feet -
Cover boats, PWCs, RVs, golf carts, motorcycles, and cars.
- Protect your investments from sun, weathering, and damage.
- Keep your boat clean and secure.
- 7-year limited warranty.

(877)679-2217 touchlesscover.com

Features

11 It's Showtime: Register now for the 45th Annual Boat Show

Read on about the activities planned for this March.

- 14 Sponsor our Boat Show
- 15 Dora Canal Cruise and Lunch
- 16 Barbecue, Wine Tasting and Fun Cruise Event
- 19 Volunteer for our Boat Show

20 What is a Valve Job?

Bill Hancock takes us through the ins and outs of understanding valves in our marine engines and learning how to make them as good as new.

26 Cruising with AOMCI

The Antique Outboard Motor Club

28 SCAMPY: A Happenin' Place

See what both the youth and adult SCAMPY programs are up to this spring and how you can join in the fun.

30 From Monaco to Leesburg. The story of *Via*.

Royalty in our own backyard! Follow this Riva's journey from the royal family in Monaco to our own Sunnyland members Paul and Karen Harrison.



Spring 2026 - Published by the Sunnyland Chapter
of the Antique and Classic Boat Society



Departments

- 5 From the Editor
- 6 From the President/Past Presidents
- 7 From the Membership Chairman
- 8 Membership Renewal / Application
- 10 The Crew of Sunnyland
- 33 In Memorium
- 34 Sunnyland Advertisers/Sponsors
- 36 Trading Dock
- 38 Calendar

On the Cover

Paul and Karen Harrison's Riva Tritone navigating through the Dora Canal on Christmas Day. This is a very special boat with a Royal pedigree. The previous owners were Prince Rainier and Princess Grace of Monaco.

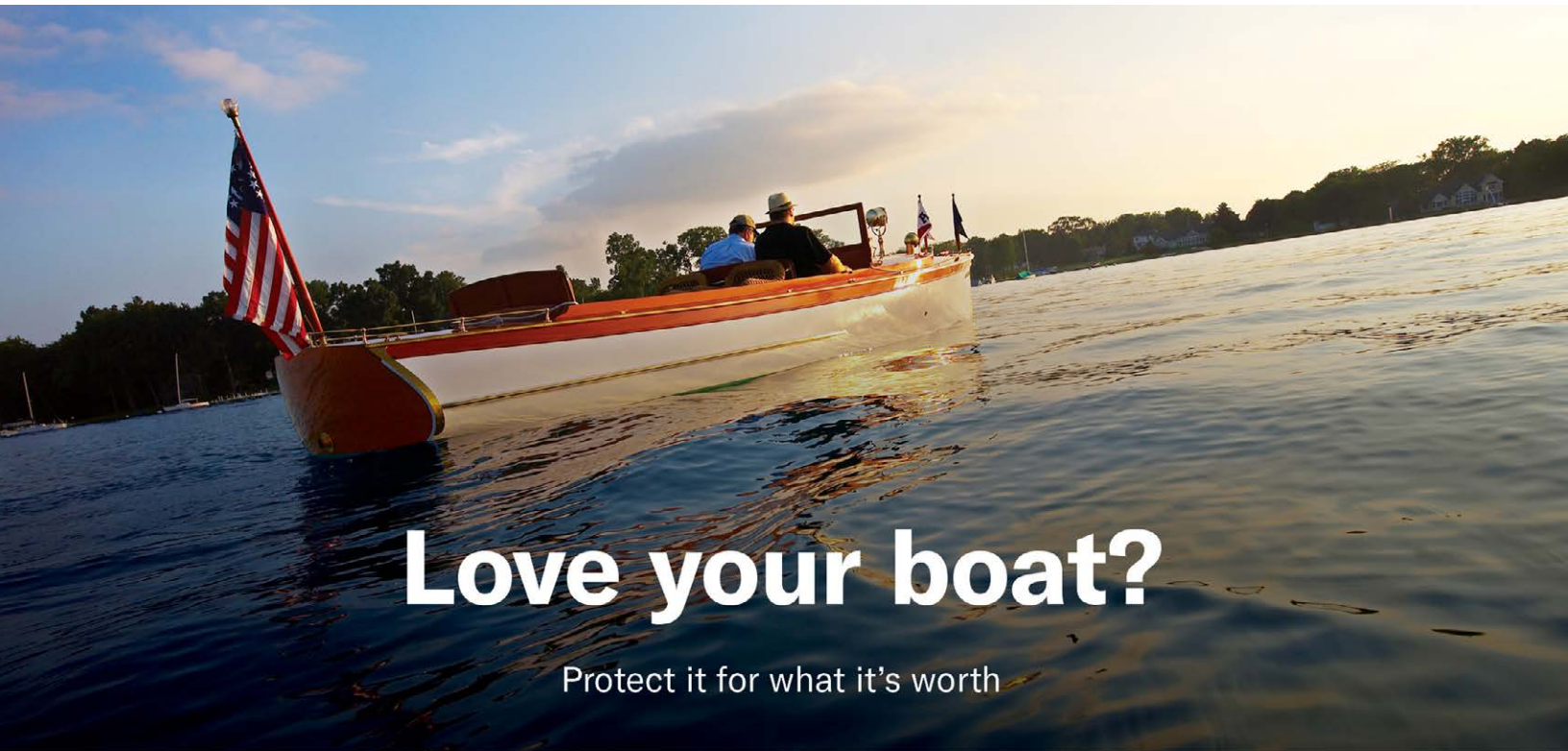
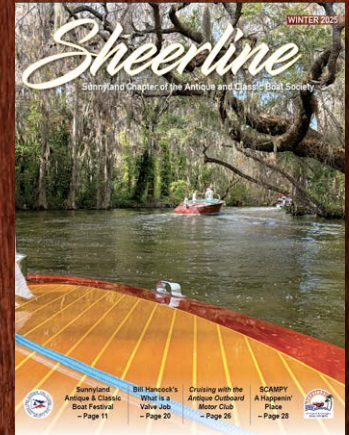

Love your boat?

Protect it for what it's worth

HAGERTY | Let's Cruise Together

800-762-2628 | Local agent | hagerty.com

Policies underwritten by Essentia Insurance Company or Markel American Insurance Company. All third party makes, models, and vehicle names are property of their respective owners. Their use is meant to reflect the authenticity of the vehicle and do not imply sponsorship nor endorsement of Hagerty nor any of these products or services. Hagerty is a trademark of The Hagerty Group LLC, ©2025 The Hagerty Group, LLC. All Rights Reserved. The Hagerty Group, LLC is a subsidiary of Hagerty, Inc.



From the Editor

Jeff Funk

This is my first Editor's Message, and would be remiss if I did not recognize Bill Robbins for his many contributions over the years to this *Sheerline* publication. Bill always downplays his role but know he has invested countless hours to make the *Sheerline* the successful magazine it is today. So, thanks, Bill ... you left some pretty big shoes to fill. Trudi and I will do our best to fill them and continue the high standards you set for the *Sheerline*.

One of our many tasks is finding good stories to put in the magazine. If you're like me, you enjoy reading about other Sunnyland members, especially their boats and boating

adventures. Many have restored their own boats and engaged in some pretty interesting boating ventures. That said, restoring a classic boat entails some of its own adventures ... which

many of us have also incurred.

If you have an interesting boating episode (and many of you do), or would simply like to share a story about your boat ... whether it's about your restoration or not, shoot me a note and let's get it in the *Sheerline*. Readers will enjoy it and appreciate your sharing. Trudi and I will always be on the 'hunt' for content to keep the *Sheerline* interesting and relevant.

Be safe out there ... and go boating!

Jeff

260-414-0016 | funkfamjj@gmail.com

Enjoy Burgers, Steaks & Seafood
with the best view Lake County has to offer.



Waterfront Dining and Balcony Seating
111 West Ruby Street
Tavares, FL 32778
352-508-5862
Open at 11am Daily
www.puddlejumperslakeside.com

Attention Snowbirds

Are you a snowbird with two mailing addresses or are you moving soon?

Don't forget to send your updated address to ACBS.

acbs.org/contact-us/
or email Dan@acbs.org





From the President
**Tom
 Drozd**

Greetings Sunnyland Members

Happy New Year! It's hard to believe 2026 is already here. Where does the time go? Welcome back to all the snowbirds and we look forward to seeing everyone boating on the lakes. Florida boating season is in full swing. Don't forget our next event is the Bar-B-Que/Wine & Beer Tasting boat run on Feb 21st. Registration and information was included in the last Sheerline. Please get those registration forms in so we have accurate numbers for planning purposes.

There are a few things I'd like to mention, the first being the SCAMPY fundraising campaign. Last year, we had an anonymous member donate \$40,000 to SCAMPY. With some of that funding, we acquired the Dodge boat that is going to be restored through the program. This year, our SCAMPY guru, Lou Ronca, has promised to match up to \$25,000 in donations to the SCAMPY program. Thank you for your generosity, Lou! He would like to make the SCAMPY program self-

sufficient through donated funds, so please consider giving so that we can achieve this goal. It will be a remarkable presentation at the Boat Festival awards breakfast.

On a second note, I have sent out 35 requests to sponsors for this year's show. In my last President's message, I asked for a volunteer to step up and chair the sponsor committee. I have taken on this responsibility myself, and since I'm not the "salesman" type, I again request a volunteer to take the reins on this. Sponsors are necessary for a successful show.

Sunnyland will be celebrating its 45th Annual Boat Festival this year on March 26-29, 2026. We look forward to reconnecting with everyone in sunny Florida, enjoying the beautiful boats and some scenic boat rides. You can also participate in two great St. John's River trips. Many of the participants that have gone on these trips come back year after year as it is an experience to remember.

Our regular meetings regarding the boat show have begun and things are coming

together. There will be some changes to this year's boat show layout. Specifically, a new road has been added behind the Citrus Hotel with additional diagonal parking. Also, a new retention pond is going in behind the Kahlua Beach Bar. I've been watching the progress on these projects, and we are told it will be completed in time for the show.

This is the first Sheerline issue produced by Jeff Funk and Trudi Miklos. We thank them again for taking on the job and give them our full support. Thanks again, Bill Robbins, for all your years of dedication to our quarterly magazine. To many members, this is the only communication they have with the club, so it is vital to Sunnyland.

I look forward to seeing everyone at the Bar-B-Que/Wine & Beer Tasting event and, of course, the Boat Festival. Happy and safe boating to all. Our next Board meeting will be at 1:30 pm on February 22, 2026, at SCAMPY.

Best Regards,

Tom

Sunnyland Past Presidents

1985-1986 Gary Scherb
 1987 Riley Richardson
 1988-1989 Dale Tassell
 1990-1991 Barney Fielden
 1992 Wilson Wright
 1993-1994 Ron Hicks
 1995-1996 Lynne Shinn

1997-1998 John Ross
 1999-2000 Bob McInerney
 2001-2002 Terry Fiest
 2003-2004 Pete Williams
 2005-2006 Gerald Dake
 2007-2008 Guy Marvin
 2009-2010 Lou Ronca

2011-2012 Craig Hartwig
 2013-2014 Bill Hancock
 2015-2016 Pete DeVito
 2017-2018 Bruce Kester
 2019-2020 Joe Coleman
 2021-2022 Danny Ross
 2023-2024 Howard Wanamaker



From Our Membership Chair

Lynn McFarlin

As I sit here tonight in mid-January and write this letter for the upcoming Sheerline, I thought about the activities here in my household. Over the past few weeks, my husband has been preparing his boat with a few fresh coats of varnish in anticipation of the Sunnyland show in late March.

After watching how much work is involved in a few new coats of varnish, it occurred to me how much work it takes to put the boat show together, both individually and at a chapter level. With this in mind, I would like to encourage all members to attend and volunteer at the show. If you are interested in volunteering, please contact Howard Wanamake (howardwanamaker@gmail.com) or Terry Fiest (tfiest@att.net). This is a great opportunity to pitch in, reacquaint with old friends, and make new acquaintances with chapter members.

During the show I will be manning

the Membership tent. Please stop by and say “Hello”, maybe sit a while under the tent to get out of the sun and chat about boats. Also, the cocktail party on Thursday at the Pavilion is a great opportunity to mix and mingle with the chapter members. It is a great venue and I encourage all to attend.

I am reminding all ACBS member to log into their account at ACBS.org to verify and update all their email, address, and phone information. You can also manage your annual dues via the membership portal. As I am sure you are all aware, communication is primarily through emails. If your email address is not up-to-date, a lot of information may not find you in a timely fashion.

I hope to see and talk to all of you at the show in March.

Happy Boating

Lynn

Welcome New Sunnyland Members

- Matthew Breidert
- Jason Soldini
- Ann Storandt
- David Jones
- Brad Koal Wynne Guy
- Brendon Trevett-Linder
- Maurice Frazier
- David C. Jones
- Timothy Chalfant
- Brendon Trevett-Lindle
- Donald Koenke
- Ronald Raven

Advertise in the next issue of *Sheerline* and promote your business or service to fellow antique and classic boat enthusiasts.

Call Don Taylor at 630-632-9797
or drtaylor@me.com





ACBS Sunnyland Chapter Members

Will you be renewing your ACBS Membership?

Please take the time to renew your membership today or drop us a short email letting us know you have decided to cancel your membership.

You have 3 options to renew:

1. Online through the Member's Portal, www.myacbs.org. Log-in using the email address you filed with your membership. When your profile opens, review your contact and boat information. Use "Edit My Information" to make any changes, then click SAVE. Once your profile page has been updated, click on the green "Renew" button (top right).
2. Call the ACBS Headquarters at 315-686-2628 during business hours, M-F, 8:30am-4pm
3. Mail the Membership Applications to:
Lynn McFarlin, Sunnyland Chapter Membership Chair
14174 Fort Worth Circle, Port Charlotte, FL 33981

When renewing your membership, please review your membership profile. If you have a seasonal address change, check that the mailing dates are correct. You may edit, delete, or add a boat(s) to your membership profile and you may add a picture and a short history of each boat. You can also add secondary Chapters to your membership.

As an organization, ACBS appreciates your membership.

Sharing your interest with others not only strengthens our organization as a whole, but also creates friendships that last a lifetime. Check out the ACBS Calendar to see all the local Chapter events scheduled in your area!

Sunnyland Membership Application



Name _____

Mate's Name _____

Address _____

City _____ State _____ Zip _____

Home Phone _____ Mobile _____

Email _____

Yearly Dues

To join the Sunnyland Chapter you must also join ACBS. If you are already a member of ACBS enter your number _____ and pay Sunnyland dues only.

New Renewal

ACBS dues \$75 US

Sunnyland dues \$25 US

ACBS Membership Directory \$20 US
(printed)

Total - Make check payable to ACBS \$ _____

Boat Information

List additional boats on separate sheet

Year _____ Builder _____ Model _____

Boat Name _____

Length Overall _____ Hull No _____ HP _____

Engine Make _____ #Cyl's _____

Year _____ Builder _____ Model _____

Boat Name _____

Length Overall _____ Hull No _____ HP _____

Engine Make _____ #Cyl's _____



Membership dues include membership to The Sunnyland Chapter and Antique and Classic Boat Society (ACBS), plus you'll receive one-year (4 issues) of *Sheeline* and *The Rudder* magazines.

Mail Completed Form with Check to:

Lynn McFarlin, Membership Chair
ACBS/Sunnyland Chapter
14174 Fort Worth Circle
Port Charlotte, FL 33981



Sunnyland Crew

OFFICERS

Tom Drozd, President

312-907-5779
tomdrozd@hotmail.com

Dan Ross, 1st Vice President

203-808-2192
danrossfd@yahoo.com

Frank Miklos, 2nd Vice President

412-974-1589
tmiklos4@yahoo.com

Neil Avery, Secretary

904-955-9055
neilavery@watsonrealtycorp.com

John Hough, Treasurer

561-723-5511
pbestatelaw@gmail.com

Howard Wanamaker, Past President

757-339-0120
howard.wanamaker@gmail.com

Bonner McLemore, Director

wbmclemore@gmail.com

Bill Robbins, Director

305-213-6440
billrobb@comcast.net

Mike Yobe, Director

352-455-6271
yobeslanding@gmail.com

George Emmanuel, Director

352-378-5172
gemmanuel@bellsouth.net

Debi Weinert, Director

731-441-9158
boatsbykarl@gmail.com

Terry Fiest, Director at Large

407-351-3424
tfiest@att.net

Jerry Hardwich, Director at Large

352-217-6816
jerryhardwich@aol.com

Lou Ronca, Director at Large

407-493-855
lgronca@gmail.com

STANDING COMMITTEES

Lynn McFarlin, Membership

860-966-7189
lynn.mcfarlin2@gmail.com

Frank Miklos, Events & Activities Committee

412-974-1589
tmiklos4@yahoo.com

Gerald Dake, Philanthropy

904-221-6698
odyssey1947@bellsouth.net

Jack Wanamaker, Website Chair

757-401-7746
j.w.wanamaker@gmail.com

BOAT SHOW

Terry Fiest, Boat Show Co-Chairman

tfiest@att.net

Howard Wanamaker, Boat Show Co-Chairman

757-339-0120
howard.wanamaker@gmail.com

Chris Youngblood, Logistics

Chris125@cfl.rr.com

SCAMPY

SCAMPY Mentors:

*Mike Yobe, Scott Robinson, Vaughn McIntire,
Jim Reinking and Bill Robbins*

Mike Yobe, SCAMPY Operations Leader

352-455-2271
yobeslanding@gmail.com

Lou Ronca, SCAMPY Donation Leader

407-493-8553
lgronca@gmail.com

Frank Miklos, Marketing & Sales Leader

412-974-1589
tmiklos4@yahoo.com

Jim Card, Marketing & Sales Leader

954-655-6366
jamescard@bellsouth.net

Scott Robinson, Student & Family Recruiting

562-619-4016
woodboatfan@gmail.com

Lynn Wisniewski, Communications

Co-Leader
407-463-3277
lynnwisniewski@gmail.com

Trudi Miklos, Communications Co-Leader

724-312-3993
tmiklos4@yahoo.com

ST. JOHNS RIVER CRUISES

Christie & Kelly Daniel, South Co-Chair

770-490-5989
kellyandchristie@gmail.com

Laurie & Guy Marvin, III, South Co-Chair

904-334-3885
gmarviniiii@gmail.com

John Heiderich, North Co-Chair

864-231-9614
just2more@aol.com

Gerald Dake, North Co-Chairs

904-221-6698
odyssey1947@bellsouth.net

SHEERLINE STAFF

Jeff Funk, Editor

260-414-0016, funkfamjj@gmail.com

Trudi Miklos, Assistant Editor

724-312-3993, tmiklos4@yahoo.com

Bill Hancock, Assistant Editor, Engines & Mechanics

904-683-4898
bizweh@gmail.com

Ann Matheson, Assistant Editor

352-978-1595
mathesonlucie@aol.com

Donald R. Taylor, Director of Advertising & Trading Dock

630-632-9797
drtaylor@me.com

34048 Linda Lane
Leesburg, FL 34788

Published quarterly:

February, May, August, November

Deadline to submit stories:

January 15, April 15, July 15, October 15

Annual Advertising Rates:

| | |
|-----------------|---------|
| Full page color | \$1,500 |
| Half page color | \$900 |
| Quarter Page | \$500 |
| Business Card | \$250 |

Full payment must be received by the deadline date.



Sunnyland Chapter
of the
ANTIQUE & CLASSIC
BOAT SOCIETY



It's Show Time!

The 45th Annual Sunnyland Antique Boat Festival

March 26-29
Wooten Park
Tavares, Florida

Online registration
begins January 16.

Watch our website at
acbs-sunnyland.org
for updates.

By Trudi Miklos

This year's Boat Festival kicks off the 2026 boat show season and promises to be another banner event. Plans are coming together and we're finalizing the show layout.

Registration is now open.

Visit our website, acbs-sunnyland.org
to register for any or events.

Online registration begins January 16

Register for any or all events on our website at acbs-sunnyland.org

Thursday Night reception

The reception continues to be one of our most popular events. We will still hold the welcome reception at the Pavilion, and it will continue to be a ticketed event. When you register for the show, you will have the option to select this event.

Saturday Ladies' Luncheon and Fashion Show

Saturday from 10am – 3pm When you register for the show, you will have the option to select this event.

This year, we will continue the tradition of the ladies' luncheon and fashion show. The show this year will be held in the Pavilion, the same location as the Thursday reception.

If you haven't been to the Pavilion, you are in for a huge treat! It is a beautiful building and will make a wonderful backdrop for a delicious lunch from Pisces Rising and a fun fashion show, hosted by Claire at Ms. on 5th Avenue in Mt. Dora. It's a great time for the ladies of the show to kick back, enjoy some time to socialize, and maybe find a couple new "must have" pieces.

Saturday Sunnyland Happy Hour

This year, in lieu of a banquet, we will host a casual happy hour opportunity on Saturday evening at the show site with appetizers and discounted drinks. This will be a ticketed event that you can choose when you register.

Sunday Breakfast

This is a new addition to our activities. As part of your full show registration, you will be able to join us for breakfast prior to the awards ceremony. We encourage all show participants to attend, socialize over breakfast, and stay for the presentation of the awards. Afterwards, you are free to walk the show one final time before pulling your boat. Many boaters enjoy taking a Sunday morning cruise around the lakes and through the canals before loading up your boat and heading out. The breakfast is open only to those with a full show registration, and is included in your show registration cost.



In addition...

Thursday Dora Canal Cruise

Separate from the show registration is a Thursday Dora Canal Cruise, culminating with lunch at Ski Beach restaurant in Leesburg. For more information, see the article elsewhere in this edition of the Sheerline. There is no registration necessary for this canal cruise, but we are asking people to RSVP to Jeff Funk so he can get a head count to the restaurant.

Sunnyland Hospitality Tent

Another fun addition to the boat show will be the addition of the Sunnyland Hospitality Tent, near the Corporate Sponsor area. There, you will be able to purchase beverages and light snacks, without having to leave the show site.

Food Trucks and the Dora Queen

As always, there will be food trucks, as well as the bar area of the Dora Queen to cool off while walking the docks. We will also have the main hospitality tent on the East End of the park to enjoy your lunch or just to take a break for the day.

We will not be hosting a Friday afternoon picnic or a Friday evening get-together, and instead encourage attendees to spend the time catching up with old friends and getting to know new ones. The Tavares/Mt. Dora area offers many, many dining and entertainment options.

Additional Show Participants

Again this year, we will have the Gaspar club, as well as the Antique Outboard Motor Club with their displays, other marque clubs, and numerous land display boats.

At noon on Saturday will be the Amphicar parade – you don't want to miss this fun event!

The Nautical Flea Market is a great place to score those hard-to-find parts, as well as nautical merchandise and information on



services that boaters need.

The Ship's Store will move down closer to the docks this year, but will still have a full range of show merchandise.

Field of Dreams

Make sure you plan a stroll through our Field of Dreams – the boat you've been waiting for is waiting there for you! If you have a boat to sell, you can handle that through our online registration system as well. You can choose the You Pick option, or you can choose the Sell a Boat link to take you quickly through the process. Note that with the Sell a Boat option, you will NOT have the choice to select additional events or crew members. Use the You Pick option if you want to place a boat in the Field of Dreams AND select events and/or additional crew members.

Registration

Entry price remains the same as in past years, just \$10/person for the entire weekend. Children under 18 are free. You can pay for



your gate entry at the pay gates, or you can register online, even if you're not bringing a boat. All online registrants will receive a show "goody bag," including a poster. If you want to attend the Thursday Reception, the Ladies' Lunch on Saturday, or the Saturday Happy Hour, you do need to register in advance. VERY limited tickets will be available at the show, if at all, depending on

pre-registration numbers.

Registration will be open briefly on Wednesday evening, on Thursday from 7:30 a.m. – 5 p.m., and from 8 a.m.-noon on Friday. No registrations will be accepted after noon on Friday. The registration trailer will continue to be located on Joanna St, at the Ruby Street intersection. We cannot guarantee space for your boat if you do not pre-register. ✦

If you have questions about registration, contact Trudi Miklos at tmiklos4@yahoo.com or 724-312-3993.



Sponsor our Boat Show!

Sponsor opportunities are once again available for this year's festival. This will be the sixth year we have had an expanded waterfront featuring a new marina and dockage at Wooton Park, Tavares, Florida, with over a one-third mile of waterfront and show area on Lake Dora. We have several levels of support for sponsors to choose from for the 2026 show.

Sunnyland is the Florida chapter of the Antique and Classic Boat Society Inc. (ACBS), an international organization for boating enthusiasts. With 400 members, we are ACBS's largest chapter and have hosted our annual boat show, now in its 45th year, entirely with volunteers. The event features approximately 150 boats and attracts thousands of both international attendees and local visitors.

Platinum

Our most prestigious \$5,000 and upwards level.

As a Platinum level sponsor, you will receive show passes and identification badges, invitations to the Tavares City Reception Cocktail Party, the Sunnyland Show Cocktail Gathering on Saturday evening, and breakfast at the awards presentation on Sunday morning. Every sponsor selects a boat to win their sponsored award. Also included is advertisement in our award-winning *Sheerline* magazine, a quarterly publication, and your logo and company name printed on various show materials.

Contact the show chairman for all the details and benefits available for your marquee show space.

Nautical Gold Sponsor

Our most seaworthy opportunity for you and your crew of seven mates at the \$2,500 level.

Included in the Nautical Gold Sponsorship are eight (8) show passes/identification badges, invitations to the Tavares City Reception Cocktail Party, the Sunnyland Show Cocktail Gathering on Saturday

evening, and breakfast at the awards presentation on Sunday morning. Every sponsor selects a boat to win their sponsored award. Also included are four (4) full page advertisements in our award-winning *Sheerline* magazine, a quarterly publication, and your logo and company name printed on various show materials.

Your provided promotional materials will be added to the participant gift bag. Also included is a 20' x 20' tent site with 2 tables and 6 chairs, (electricity is also available) room for four (4) land display boats and one (1) in water docking slip.

Nautical Silver Sponsor

Our most dockable opportunity for you and your crew of three mates at the \$1,500 level.

Included in the Nautical Silver Sponsorship are four (4) show passes/identification badges, invitations to the Tavares City Reception Cocktail Party, the Sunnyland Show Cocktail Gathering on Saturday evening, and breakfast at the awards presentation on Sunday morning. Every sponsor selects a boat to win their sponsored award. Also included are four (4) half-page advertisements in our award-winning *Sheerline* magazine, a quarterly publication, and your logo and company name

printed on various show materials.

Also included is a 10' x 20' tent site with 2 tables and 4 chairs, (electricity is also available) room for two (2) land display boats.

Nautical Bronze Sponsor

Our most beach-able opportunity for you and your crew mate at the \$500 level.

Included in the Nautical Silver Sponsorship are two (2) show passes/identification badges, invitations to the Tavares City Reception Cocktail Party, the Sunnyland Show Cocktail Gathering on Saturday evening, and breakfast at the awards presentation on Sunday morning. Every sponsor selects a boat to win their sponsored award. Also included is special mention in our award-winning *Sheerline* magazine, a quarterly publication, and your logo and company name printed on various show materials.

Your provided promotional materials added to the participant gift bag. Also included is a 10' x 10' tent site with 1 table and 2 chairs.

Mates Virtual Sponsor

Our latest addition is a hostless presence at the \$250 level.

Your product or service will be displayed along with the other corporate sponsors' tents.

Your brochures, signage, and trinkets will be displayed on a table. Also included is special mention in our award-winning *Sheerline* magazine, a quarterly publication, and your logo and company name printed on various show materials.

For more information:

Contact Tom Drozd at 312-907-5779 or tomdrozd@hotmail.com for more information. You can also find a sponsor registration form on our website, acbs-sunnyland.org, under the Boat Festival tab. 2026 forms should be available online soon.



Dora Canal | Cruise & Lunch

As most of you know, there will be no Friday event boating to lunch at Hickory Point this year. Spectators paying to attend the show on Friday have commented that many boats are absent...gone to the picnic. Attendees want to see all the boats. This has been a request from paying guests for years.

Instead, we are bringing back the Dora Canal Cruise. It will be on Thursday, March 26th. We plan to leave the Tavares docks at 11:00 a.m. We will travel through the historic and beautiful Dora Canal, cross a small section of Lake Eustis, head west through the Dead River into Lake Harris. From that point, we will continue heading west on Lake Harris to the waterfront Ski

Beach restaurant in Leesburg.

Ski Beach has ample docking which can accommodate twenty boats or more. Following lunch, boaters will make the one-hour trip back to Tavares. Fuel, if needed, is available at the neighboring Venetian Marina, next to Ski Beach. Boaters may wish to continue exploring the Harris Chain of Lakes, or make their way back to Tavares with the group. We plan to return to the Tavares docks by 4:00 p.m.

Make sure you complete your show registration checkin at the Registration Booth on Joanna St. prior to leaving the docks. Registration will close shortly after our anticipated return time of 4 p.m., and only very limited

registrations will be able to be completed on Friday. If you have concerns about completing your registration Thursday morning, please contact Trudi Miklos at tmiklos4@yahoo.com.

There is no registration or lunch fee for the Dora Canal Cruise; you are only responsible for your lunch bill. We are asking for those interested to contact Jeff Funk so he can obtain the number of boats and attendees for Ski Beach.

Of course, if the weather does not cooperate, the Cruise will be canceled. Please let Jeff know if you plan to attend at your earliest convenience. ✦

Jeff Funk | funkfamjj@gmail.com

REGISTER NOW FOR SUNNYLAND'S ANNUAL

Barbecue, Wine Tasting and Fun Cruise Event

SATURDAY, FEBRUARY 21, 2026

Back again this year...

We've again extended an invitation to the Heart of Florida Model A Restorers Club (HOFMARC) and the British Car Owners to join us. We think it's a great idea to have both vintage boats and classic cars on Display at Hickory Point for our annual event. Whether by boat or car it's unique – please join us.

Barbecue and Wine Tasting

This highly popular Sunnyland event is scheduled from 12 noon to 2pm at the Hickory Point Recreational Park in Tavares. Food will be provided by OakWood Smokehouse & Grill and wines by Maggie's Attic. The park is located about four miles south of Tavares, adjacent to Little Lake Harris at the north end of the Howie Bridge, and offers ample parking and a sizable day-use marina.

No overnight mooring.

Admission to the park is FREE – glass containers and alcoholic beverages are forbidden.

27341 State Road 19
Tavares, FL 32778
(352) 343-3777
www.lcwa.org
Lake County Water Authority

Cruise of the Harris Chain of Lakes

For those participating (i.e., weather and "intestinal fortitude" permitting), this cruise will start at 10am at Gilbert Park in Mount Dora. Boats will cruise through the Dora Canal and Dead River and gather at the Hickory Point Recreational Park by 11:30am.

Ride Sharing (No Boat? No Problem!)

To accommodate our out-of-town (or currently "boat-less") members, please let us know if you have space on your boat and are willing to share a ride. If you're looking to hitch a ride, contact us for details.

Weather

The weather at this time of the year can be rather chilly; highs are expected to be in the mid to low 70s, with lows in the mid to low 50s. Typically, February in Tavares is mostly cloudy, the chance of precipitation is around 25%, and water temperatures are less than 70°F.

Registration

Please fill out the accompanying registration form, make your checks payable to "Sunnyland Chapter ACBS", and mail both as soon as possible to:

Tom Drozd
2508 Baywater Rd.

Tavares, FL 32778

Any questions may be directed to Tom at 312-907-5779

REGISTRATION FORM

Barbecue, Wine Tasting and Fun Cruise Event

SATURDAY, FEBRUARY 21, 2026

Skipper's Name: _____ ACBS Membership#: _____

Name(s) of Additional Crew members: _____

Street Address: _____

City: _____ State: _____ Zip: _____

Phone: _____ Email Address: _____

Boat Name: _____

Manufacturer & Model: _____

Length & Year: _____ Number of Passengers I Am Willing to Add to My Crew: _____

Registration Cost for Cruise, Lunch, and Pavilion

You may view the boats and cars on display without eating or drinking for no charge.

Food only @ \$30/per x _____ No. of people = \$ _____

Wine only @ \$11/per x _____ No. of people = \$ _____

Combo Food Wine \$41/per x _____ No. of people = \$ _____

Total Remitting = \$ _____

Please read and sign the following Liability Waiver:

For myself and any member of my family, including all minors who accompany me or should otherwise participate in the above named event, I hereby waive any claim for injury to my person, boat, or equipment. I agree to hold harmless the Sunnyland Chapter of the Antique and Classic Boat Society and any and all other sponsors of that event, their employees, agents, and volunteers and assistants for any injury or loss suffered by me, my family, or any invitee during or in connection with the above mentioned event, whether such injury or loss resulted directly or indirectly from the negligent acts or omissions of said sponsors, employees, volunteers, assistants or others connected with the above mentioned event. I understand that in order to participate in this event my boat must be adequately insured.

I am a member of HOFMARC British/Other Car Owner

Car Owner _____

Street Address: _____

City: _____ State: _____ Zip: _____

All Participants

Signature & Date: _____

Attach check (payable to Sunnyland Chapter ACBS) and Registration Form/Liability Waiver and mail by February 5th to Tom Drozd, 2508 Baywater Rd., Tavares, FL 32778.



President Tom Drozd and First Vice President Danny Ross were on hand to present a check at the U.S. Marine Corps Reserve Toys for Tots Foundation event. The event took place at the Eustis Boat Club on December 7, 2025. A very big thank you to all the Sunnyland members who generously donated to the cause.



CLASSIC BOAT COLLECTIVE

The Next Generation In Classic Boating

**Your Go-To Source For
Buying And Selling Classic Boats**

**Over 80 Years Combined
Experience!**

315-608-0551
classicboatcollective.com
47625 CR-1 Redwood, NY 13679



**VIEW
INVENTORY**



BUY | SELL | RESTORE



VOLUNTEER FOR SUNNYLAND ANTIQUÉ BOAT FESTIVAL

SHOW DATES – MARCH 26-29, 2026

The Antique Boat Festival, March 26-29, held in Tavares at Wooten Park, is fast approaching. The Sunnyland Boat Show Committee Chairs have asked for the Sunnyland membership to join in and enhance the guest and member experience by volunteering for a few hours.

Volunteers will staff the pay gates, assist the various committee chairs as needed, and be available to answer guest questions throughout the show. We're looking for volunteers to work one 4-hour shift over the 3 ½ days of the show, leaving plenty of time for attending the show.

Volunteers with some knowledge of the show, the boats, and/or antique boating in general are always welcome. These volunteers can answer questions from the public about our hobby. However, we have volunteer opportunities everywhere, no prior experience needed! If you're hosting friends and family during the show, they are welcome to tag along and help out as well. Volunteers are all given free admission for the entire weekend for just one 4-hour shift. That's a great deal!

We are also still looking for a sponsor committee



chair and a volunteer organizer. Both of those positions can be filled by a single person or a team. If you think you could help in either of those capacities, we would be very grateful.

To sign up, you can use the link on the website under the Show Registration page. This link will be available after registration opens mid-January. Our website is acbs-sunnyland.org. We will be continually updating our website between now and the show, so please check it out on a regular basis for answers to all your questions. ✦

What
is a

Valve Job



By Bill Hancock | Assistant Editor

Bill is a retired engineer with extensive experience in auto racing, engine design and problem solving.

We have all heard the term, but what does it mean? The intake and exhaust valves in our engine let the air in and the exhaust out, similar in shape and function to the drain valve in our bathtubs.

Over time, as the valve stems and guides wear, the valves lose their ability to seal which reduces the power output of the engine, and increases oil consumption. This wear is gradual and the loss of performance is not noticeable since we rarely run at maximum power. The telltale oil smoke coming from the exhaust and oily residue in the exhaust pipe will often be the first sign of wear.

So how do we fix this problem?

Let's begin by examining the components which directly affect the valves' sealing ability. In most antique and classic boat engines, each cylinder typically has two valves: intake and exhaust.

The valve travels up and down in a round sleeve called a valve guide. When the engine is new, the clearance between the guide and the stem of

the valve is typically less than .002". For reference, a human hair is typically .003"-.004" in diameter. The valve head seals against the valve seat located in either the cylinder head or the block depending on the design of your engine. The valve seat is machined concentrically with the guide, thus providing a good seal when the valve is closed. To ensure this seal, the valves are held in place against the seat by springs.

Depending on the engine, the valves may be located in the block or in the

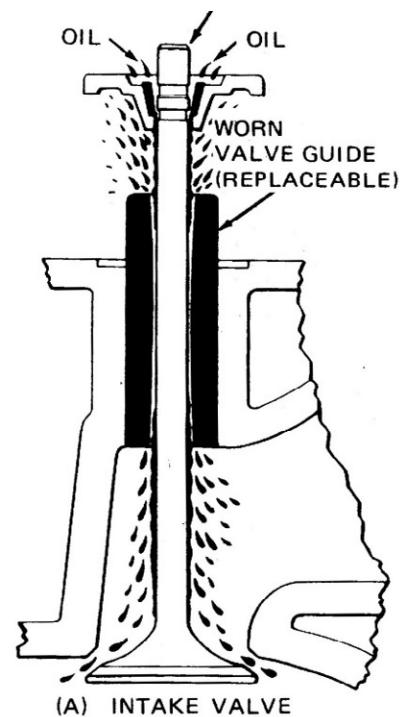

A cutaway showing a typical valve and head arrangement.

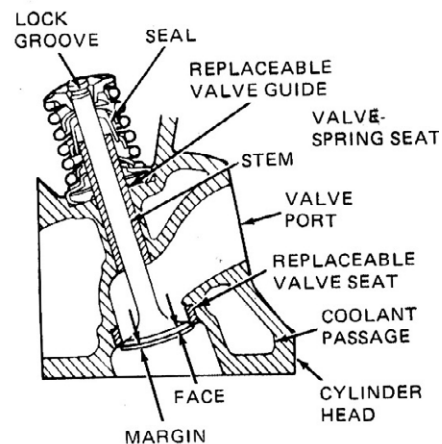

Here we can see the layout for an overhead valve arrangement where the valves are located in the cylinder head. The cutaway shows the various components which will be covered.

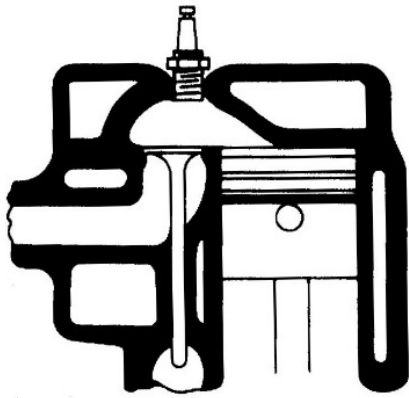

L-HEAD
(FLAT-HEAD)

A valve located in the block, which represents the valve location in many of our early antique boat engines.

cylinder head. For this article, we will assume a V-8 overhead valve engine where the valves are located in the cylinder head.

The engine has 750 hours and is down on power and burning some oil. Here is where a compression check and leak-down check will aid your diagnosis. The compression check measures the cranking pressure developed in a non-firing cylinder and produces a picture of the overall sealing of the individual cylinder, allowing you to compare with readings from the other cylinders. The leak check, which measures static pressure differential for a cylinder compared to the base pressure, will give a more detailed look at each cylinder's sealing performance by identifying where the leakage is occurring. In most cases, cylinder leakage is a combined function of the valves, rings, bore, and piston wear. In some cases, a broken ring, cracked valve or broken valve spring will cause an anomaly in the results and highlight a greater problem than routine wear. The cylinder leakage test will highlight the individual leak paths. For example, if, while performing a leak check on a cylinder you opened the throttle and heard the hiss of escaping air, it would indicate a leaking intake valve. Conversely if you held your ear over the breather outlet, escaping air would indicate leakage past the rings.

Holding your ear to the exhaust and hearing no noise would indicate no appreciable loss past the exhaust valve. Most engines at 750 hours will have a combination of leakages.

To begin, gather as much information as possible about your engine. Publications such as owners and service manuals, combined with engine data plates are essential since identically appearing engines can be vastly different internally. In this case they can have different valve sizes and different springs. Review the information about specifications and disassembly procedures. Watch a few videos to get a feel for the process. Next, look around and make sure the necessary replacement parts are available. Some parts such as valve springs, stem seals, guides, and shims, have readily available generic equivalents, and in some cases newer existing valves can be remachined to fit earlier engines.

Unlike some of our other articles, a valve job requires a trained machinist and some rather specialized equipment to rebuild a cylinder head or do a valve job. Our goal here is for the reader to understand what is entailed in a valve job to make better maintenance decisions for their engine. Unless you are in the engine rebuilding business, chances are you won't have the myriad

A Word of Caution

A valve job alone may not cure excessive oil consumption. Often people are disappointed when they get a valve job done and fire up the engine, only to learn that it smokes worse than it did before the valve job. Their immediate thought is to blame the shop or machinist for bad work, when in fact the valve job is not at fault. With a proper valve job, the valves seal very well, forcing all of the newly regained cylinder pressure to escape past the old worn piston rings and cylinder bore. So, before you decide to do a valve job, consider a complete overhaul. If the valves are leaking, the cylinders are probably ready for a refresh too.

of specialized tools and equipment necessary to accomplish a valve job. Presenting what is entailed in a valve job and whether it is necessary is our goal in this article.

We begin by removing the cylinder head/s. Until you make a determination of what to save, keep the valves in order as they come out



A valve gear board keeps all the individual components in proper order so they can be reassembled in their original positions if they are being reused.

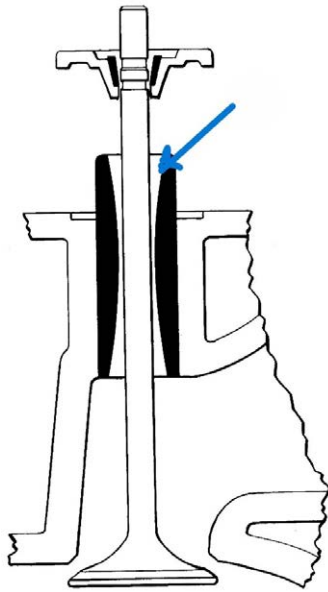

A cutaway with the blue arrow showing a valve guide with exaggerated wear

of the heads. Mark the heads with a permanent stamp so they can be returned to their original locations, and carefully keep the valves in order, since they have established a wear pattern in their respective valve guides. **DO NOT STAMP THE VALVES.** Stamps create stress risers which turn into cracks, resulting in broken or cracked valves.

The head/s and valve gear components must all be thoroughly cleaned to remove grease and carbon deposits so they can be properly inspected for

damage and wear. In probably 80% of valve jobs, the guides are worn out of spec, so they will require rebuilding or replacement. Worn guides allow the valve to wobble around thereby allowing misalignment which prevents an effective seal when closed. The increased stem-to-guide clearance combined with worn seals also causes oil leakage past the valves resulting in excessive oil consumption.

Numerous options for guide restoration and replacement are available. There are two basic types of guides; *integral* which are part of the casting and *replaceable guides*, which are separate from the base casting. The replaceable guides are pressed in, thus allowing them to be driven out and replaced by new ones.

The integral guides must be bored out to a larger diameter and reamed to accept replacement guides. In some



Replaceable valve guides are available in both bronze or cast iron.

cases, integral guides can be restored by a process known as knurling. A special knurling tool is forced down the guide, raising the surface much like threads, which is then reamed back to original size. Back in the day, this was used by used car lots as a quick fix for “smokers”. Today the best repair is to remove or bore out the original guides and install replaceable ones, thus ensuring the critical fit between the guide and valve stem is correct.

The guides have a small seal which fits over the guide and rides on the valve stem thus preventing excess oil from traveling down the stem. Depending on the style of seal, the guides may need to be machined to accept the seals which are going to be used.



Various valve stem seals are available in many different shapes, sizes, and materials.

Remember, the seal must have adequate clearance between the bottom of the valve spring retainer and the top of the seal when the valve is at full lift to prevent being crushed when the valve opens.

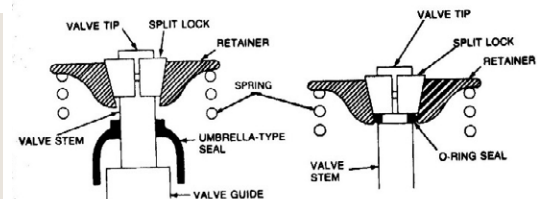

Cutaway showing two options for valve stem seals

Inspection

While this article focuses on a valve job, other things can affect the sealing of a cylinder such as a leaking head or intake gasket. So, when inspecting the cylinder head, and related parts, take a moment to examine the involved gaskets looking for signs of leakage. If a gasket is leaking, in most cases it will be because of a warped surface or improper clamping load from the surrounding fasteners, so as you are disassembling the parts pay attention to the torque required to remove the fasteners and take a moment to inspect the mating surfaces for flatness. Without precision equipment, the easiest way to measure flatness is to clean the surface using a razor scraper, then use a piece of thick (3/8”) glass coated with some lapping compound and rub the glass it back and forth over the area in question. The resulting wear pattern will quickly highlight any low areas. Since the part will be going to the machine shop, mark the problem area and have it resurfaced.

Once the guides have been replaced or reconditioned, the valve seats must be measured and inspected. In some cases, cylinder heads have removable hardened valve seat inserts to reduce wear. If necessary, these seats can be removed and replaced, or the original integral seat can be bored out to accept a replacement seat insert.



Replaceable valve seat inserts come in a large variety of sizes and thicknesses as well as materials ranging from cast Iron to hardened steel.

Once any seat work is done, a special grinder or cutter which pilots off a temporary mandrel located in the guide bore is used to reestablish a concentric seat. The seats can then be ground or machined.

The seat width and position can be adjusted by machining or grinding the upper and lower areas called the throat and top angle located above and below the seat. The width of the finished valve seat is important because aside from sealing, it also conducts heat and aids in flow past the valve.

Next, the valves are inspected and the stems are measured for diameter and



A Serdi™ seat and guide machine. This is the premier piece of equipment used to machine the valve guides and seats. It features an air-float table and precision carbide cutters which can cut a very accurate valve seat in a tenth of the time required to grind one.

wear. Considering time, effort and wear, if new valves are available, it is more economical and much safer to just replace them. If new valves are not available, the old ones must have the

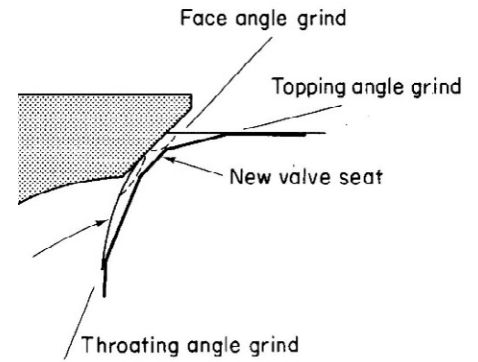

This shows the top and throat angles which are ground in what's referred to as a three-angle valve job. This allows the valve seat to not only be properly positioned but also maintain the proper width.

stems reconditioned by polishing and possibly honing the outside diameter to remove the wear patterns and to reestablish the correct geometry if possible. The stem to guide fit is critical.

Once the stems are in shape, the valve faces can be ground to restore their concentricity to the stem. A special grinder which pilots off the valve stem

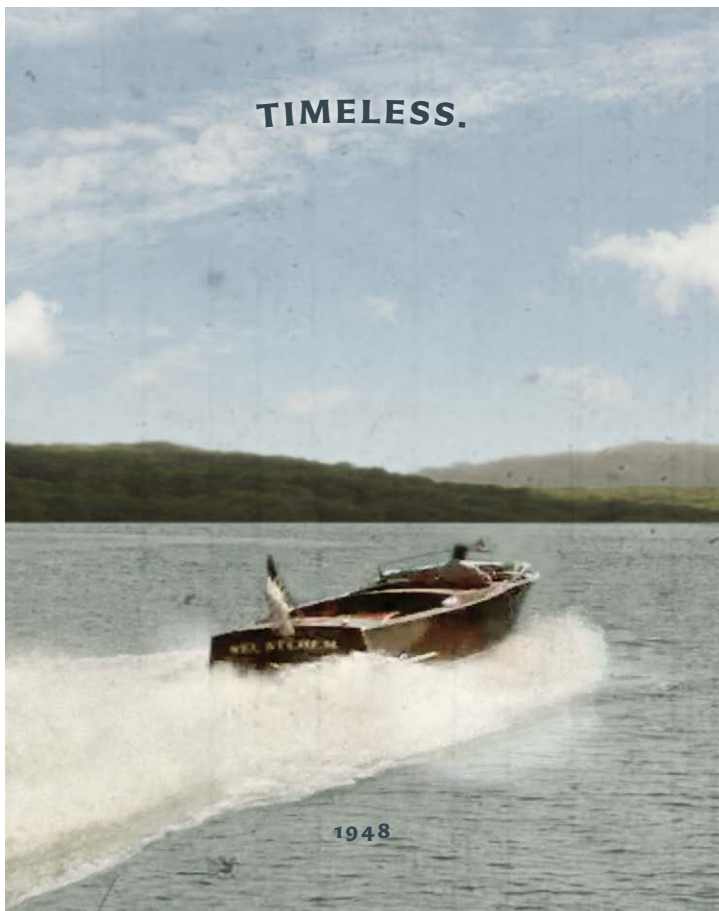

TIMELESS.

1948



UPDATED DAILY.

WoodyBoater

Live the Woody Boater Life on WoodyBoater.com

2016



A valve seat runout gage used to determine the concentricity of the valve stem to the valve seat. A good valve job will have less than .001" eccentricity or runout.

is used to grind the face of the valve, and also the tip of the valve.

Since grinding both the valve seat and valve face removes material, the valve tip height increases. To reestablish the correct tip height, the valve tip can be ground up to .020 to compensate. Proper tip height is important to retain to ensure the correct valve train geometry.

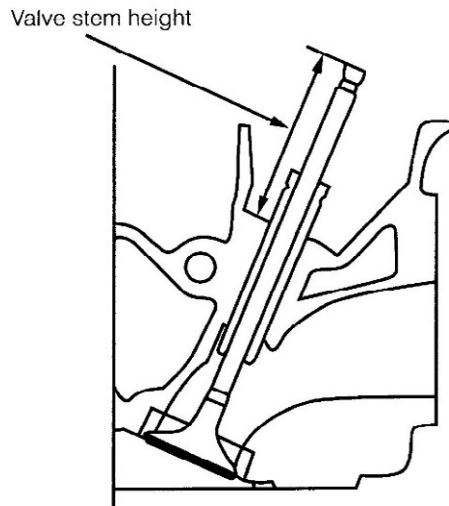

The valve tip height measurement is shown here.

The valve springs are subject to weakening and breakage, so as part of a valve job, they must be inspected for damage, and replaced if necessary. If the valve springs are still serviceable, they must be load checked and have the new assembled height measured and adjusted for load, once the valves and valve seats have been resurfaced.

Valve spring seated load is the load exerted on the valve when the valve is in the closed position. Typically, a valve job results in an increased assembled height which translates into reduced spring load while on the



A Modified Rimac™ valve spring load checker measures the given load at a given height allowing the valve to be shimmed until it meets the required load at the given assembled height.

seat. To determine the new assembled spring height, each individual valve, must be preassembled in the head with its matching retainer and keepers and have the overall assembled spring height measured.

With this height, the designated spring can be matched for load and shimmed to deliver the correct load at the installed height. Special valve spring shims are available in



Special valve spring shims are available in a variety of thicknesses as well as different inside and outside diameters, allowing users to easily achieve the correct valve spring seat loads.

A Kwik-Way™ valve grinder which is capable of grinding various valve seat angles as well as grinding and chamfering the tip.

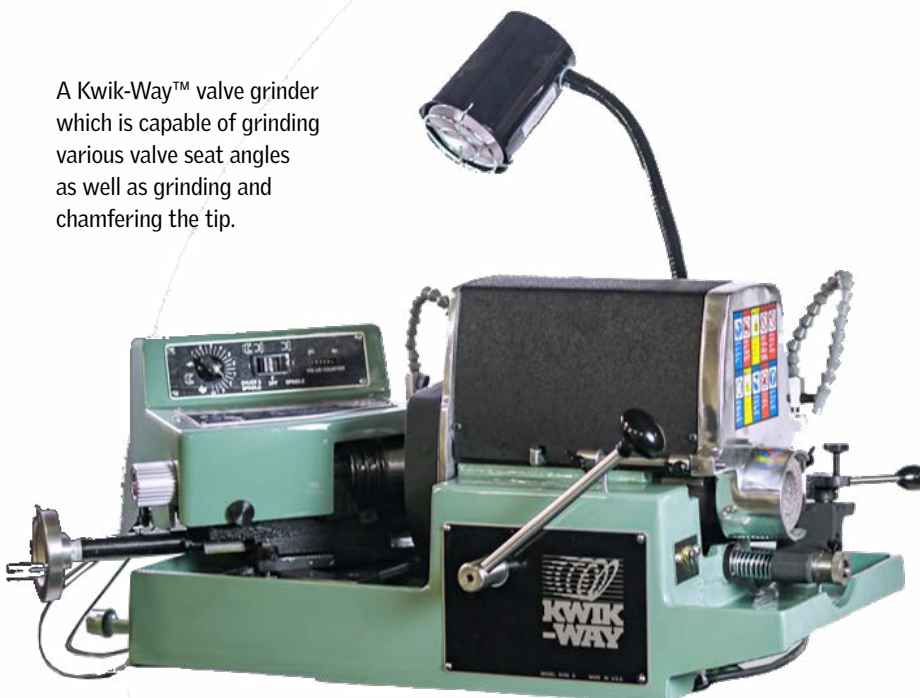

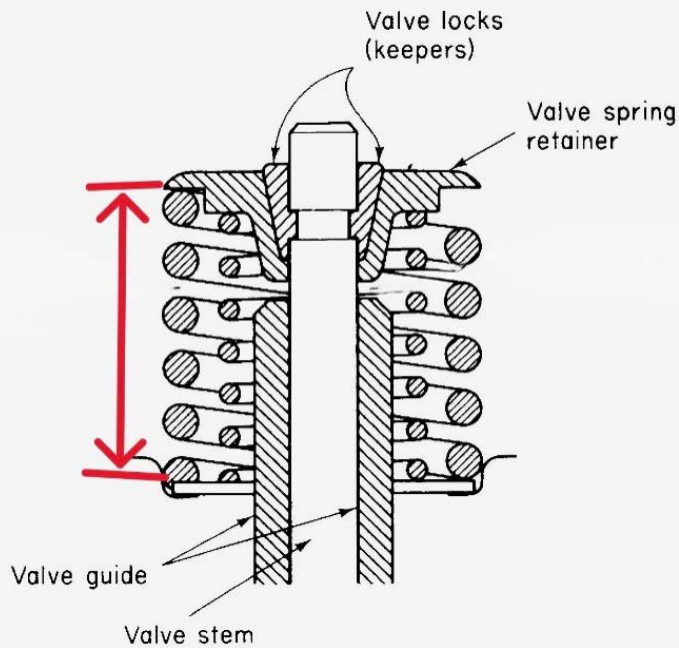

The red arrow depicts the valve spring assembled height.

different diameters and thicknesses to compensate for load variations.

Assembly

As with everything in an engine, cleanliness counts. Grinding, and machining the guides, seats, and valves creates the worst type of grit. Before reassembling the parts, make sure to thoroughly clean all of the parts, using chemicals and brushes. Finish off by washing the parts in a hot detergent bath, followed immediately by blowing off with compressed air and applying a rust preventative immediately.

After the engine is reassembled, the valves must be adjusted to the correct operating specs. Refer to your engine manual or spec sheet to obtain the correct operating procedure. For mechanical valves, Rotate the engine until both valves are closed and the piston is at the top of its travel, known as Top Dead Center firing or simply TDC. Insert a feeler gage between the valve tip and the lifter or rocker arm. Back off on the adjustment until you can insert the feeler gage between the two parts, then slowly close the gap while moving the feeler gage back and forth. When this movement requires some effort, stop and tighten the adjusting mechanism then immediately recheck the gap. Until you do this a few times, it will take a few tries to get it right.

Hopefully you now have enough general knowledge to decide whether you need a valve job, and just what is entailed. Choose a machine shop carefully.

Good luck with your repair. ✦

The worst part and the best part of our job.



When Dave Bortner saw the number on his phone, he assumed it was the customer in South Carolina he had spoken with just a few weeks earlier. So he was surprised when he heard a woman's voice on the line. She shared the unfortunate news of her husband Frank's passing. She confided that Frank had suggested she call Dave to help find a good home for their cherished 1959 Hemi-powered Century Coronado. After two months and treks to South Carolina, Florida, and finally back to Minnesota—the boat was eventually sold to a delighted customer in Texas.

Frank's granddaughter sent us this thoughtful note: "What could have been an albatross was avoided. Selling the boat would have been overwhelming for my grandmother, but because of Dave's kindness this was one less thing she had to worry about while grieving. Our family will forever be thankful that Dave was there in such a difficult time."

Owning a great boat should be all about the enjoyment.
Let us handle everything else.



For people who love great boats.™

Lake Minnetonka, Minnesota
www.FreedomBoatService.com

© 2023 Freedom Boat Service



Cruising with AOMCI

Antique Outboard Motor Club

By George Emmanuel

I've been a member of AOMCI since the late 1980s and a member of ACBS Sunnyland since 1989, enjoying the best of both worlds. Before I became a board member of Sunnyland, it was my goal to see both organizations participating in joint events.

After all, simply belonging to a boating group does not satisfy the desire to be on the water. There must be activity! Event location requirements for inboards are different from those for outboards, and being one who has both, I understand those differences. And therein lies the difficulty in finding a suitable location. The Sportsman Club in Orlando on the Butler Chain is

one of those locations that has all the requirements, and a member of our chapter is a member there.

The Sportsman Club has excellent docks, wide boat ramp, and plenty of area for parking and vehicles with trailers. The Florida Chapter AOMCI invited all Sunnyland members to come cruise in October and join us for lunch. Everything was in place and the

weather forecast didn't cooperate! Wet weather was the prediction and that kept people, especially the inboarders, away. As it turned out, the rain cleared out by late morning and folks did get out on the water, but there were no inboards! I guess we'll have to see what next year will bring us.

A couple of years ago, Jim Dunn and I planned an event for both organizations in June, when the Florida Chapter celebrated their Annual Meeting and cruise. On Friday our group cruises for lunch at the Waterfront Grill in Eustis and we invited Sunnyland to cruise with us. Over 20 boats, inboard and outboard, attended the cruise with 52 people at lunch. This was the first opportunity to do something together and foster relationships. It was the

perfect combination of requirements for inboards. Launch at Gilbert Park and dock at the Eustis docks in front of the restaurant. The docks there are excellent for both types of vessels. The only negative was June's heat and a thunderstorm that fortunately passed around us.

This event was tied into our Saturday portion of the weekend where we set up displays, enjoy a catered lunch and run our outboards from Trimble Park. When the pandemic occurred, the county limited group sizes in Trimble and effectively shut us out. After the pandemic, the park officials concluded our group was too large and denied us future gatherings. From there we moved to Lake Shipp Park in Winter Haven for a two-day gathering. A few years later, with the expansion of the playground area, we lost our display space and had to find another

suitable spot. We have since moved to the Moose Lodge in Winter Haven, thanks to the efforts of Pete DeVito. This is a great venue, but the problem is dockage. There are limited spaces.

Once per year in January, we host a one-day swap meet located in Lake Hamilton. Everything must be for sale and we would always welcome Sunnyland members to join us and bring any marine-related items they have to sell. You might be surprised to see what inboard related items might show up! Location is the field across from the Library at 200 West Main St. Typically the third Saturday of the month.

My goal is to keep working to find a venue suitable for both types of craft. The time of the year is important to have better weather predictions and cooler temperatures with facilities that meet our needs. Perhaps a cruise to

Eustis or Boondocks in Howie in April might be a thought?

In closing, the Florida Chapter has an event almost every month. Few locations meet the requirements for inboards, but we'd love to have you come and spend the day with us. In February, we are at the 4-H Camp in Lake Placid for a 3-day weekend. April and September find us on the Suwannee River at Yellow Jacket Campground. May is the Moose Lodge in Winter Haven. June we are on Lake Talquin in Quincy at Ingram's Marina, and in November we are in Casselberry on Lake Howell. Due to the summer heat, we do not have events in July and August. Typically, our meets are on the 3rd weekend of the month and we plan to have those dates listed with Sunnyland as soon as we can confirm them. I'd love to have you join us! ✦





A Happenin' Place

By Jeff Funk

Both the Youth and Adult Programs are running at full speed. There are currently three on-going projects on the youth side. One is near completion, while the other two are running at full throttle towards that end.

Walking into the SCAMPY shop on a Saturday morning will find a buzz of activity with saws, sanders, staining, painting, assembly, and plenty of smiles from both the young adults and their mentors. The teamwork between students



and mentors is something to see. Sunnyland members should feel quite proud of the SCAMPY program and all it has accomplished.

The adult program is also moving along at full speed. By the time

you read this, the 1947 Chris-Craft Rocket R-16-111 will be stained and varnished, and ready to place the Hercules 'K' 95HP engine. Final testing and detailing is being done at this writing by instructor Herb Hall. Instructor and upholsterer

extraordinaire Frank Miklos is working on the interior. Final assembly will take some time, but the goal still remains to have the boat ready and displayed for the Sunnyland Show this March. As many as a dozen adult students and helpers have done a great job getting the boat to this point. As with the Youth Program, lots of fun and smiles to go around.

The Youth Program meets every Saturday morning, while the Adult Program meets every Tuesday and Thursday from 9:00 – 12:00. Should you have any interested in becoming a mentor, or perhaps a student in the Adult Program, please come by and join in. All are welcome. If you would like make a financial or worthy boat donation, please contact Jeff Funk or Lou Ronca. ✦

Jeff Funk
funkfamjj@gmail.com 260-414-0016

Lou Ronca
lgronca@gmail.com



Karen Harrison, captain of *Via*,
running on Lake Dora.



From Monaco to Leesburg

By Paul and Karen Harrison

In 1958, Carlo Riva sent his 13th (Hull #62) Tritone, *Via*, to His Majesty Prince Ranier and Princess Grace of Monaco. Prince Ranier would use this boat with the royal family for ten years, boating in Monte Carlo Bay.



Via at the 2025 Sunnyland Antique Boat Festival.

This 26' beauty featured new paints from the Allwetterlack firm, traditional planks of Gran Bassam mahogany, and other new technologies. The original pair of 175 hp engines easily powered

this boat then, and replacement period-correct Chris-Craft MCL engines still do today. We understand that in 1962, Riva updated the dash, gauges, and other details to current

factory standards of that time.*

In 2006, Classic Boats Amsterdam began a three-year restoration of *Via*. She was subsequently sold twice at auction, once in 2014, and again in 2019, both times in Monaco. The 2019 buyer, a local collector in Leesburg, brought *Via* to Florida, where she sat in storage for several more years – a fact completely unknown to local vintage boat hobbyists. In 2024, work began on the engines to bring the boat back to usable life. However, they could not be salvaged well enough to continue using and were replaced with a pair of completely rebuilt, in-period MCLs, with all related work completed by Ted Cartner of Antioch, IL, and Herb Hall of Tavares, FL.

It was during this engine restoration that Paul and Karen Harrison learned of the boat and were able to procure it as a mechanical project and complete the engine replacement/restoration, as well as some other minor cosmetic repairs. Just four months after purchasing the boat, the Harrisons launched *Via* on Lake Dora in March of 2025, and she made her first public appearance at the Sunnyland Antique Boat Festival later that same month.

Paul and Karen thoroughly enjoy the boat on a regular basis these days. As winter residents of Tavares, they use the boat regularly from November through April.

“We enjoy the boat but we more than anything, we enjoy using it, not just

VIA

1958 Riva Tritone – Hull 62

Originally delivered to Prince Rainier and Princess Grace of Monaco, used as their personal family recreational boat until 1968

Full restoration carried out from 2006-09 by Classic Boats Amsterdam

Engines - Pair of period correct Chris Craft MCL x 2, 175HP each, with modified Chris-o-matic hydraulic shifting and ancillaries completely rebuilt and installed in winter 2024 / 25

Engine work performed by Ted Cartner of Antioch IL. and Herb Hall, Tavares, Florida

Custom built Myco aluminum trailer and Riva shipping cradle

Sold in Monaco in 2019 and acquired by current owners in 2024

Advice, information, and support graciously accepted from Don Ayers, Bjorn Bakken, Herb Hall, Alan Weinstein

“VIA” is proudly displayed and frequently used by her owners – Paul & Karen Harrison of Calgary AB, Canada and Tavares, FL.

Riva



Via running during testing with Herb Hall at the helm.

possessing it,” says Paul. “It’s not just a bauble on a trailer. It will remain a regularly used boat as long as we own it.” “It was a learning curve to become comfortable operating the twin engines with the unique Italian-designed hydraulic shifters (which replaced the original but unlamented Chris-o-Matic shifters), but it handles well and cruises very nicely,” says Karen, the primary captain.

Although the boat was in very good shape structurally and cosmetically, Paul and Karen took the opportunity while the engines were being restored to clean and repaint the engine compartment. They stayed close to the restoration process throughout the work, but they wanted to have a hand in the actual project. Working in the engine compartment allowed them not only to participate in the restoration, but to get a close look at the structure of the boat and verify its condition. Paul and Karen are longtime classic



Via sitting pretty in the water.

boat enthusiasts. Over the years, they’ve owned about 20 different boats, both wood and fiberglass classics. “For me,” says Paul, “it’s about the experience of using and sharing them, irrespective of the material used. We’re happy to have been able to return *Via*



Captain Karen Harrison enjoying one of her first outings on *Via*.

to use and visibility, and run her out on the lakes, to be seen and enjoyed.”

**Details per Tritone Aquarama, Book One, by Piero Gibellini, October 2008, Settimo Milanese, Italy*

JOIN TODAY



priority service

MATTERS

When you need help on the water, response time is everything. Only Sea Tow® members receive 24/7 priority service.

ARE YOU A MEMBER?

SEA TOW CENTRAL FLORIDA LAKES

seatow.com | 800-4-SEATOW



THE MEMBERSHIP THAT MATTERS

©2025, Sea Tow Services International, Inc. which owns, uses and licenses its trademarks. All rights reserved. No implied licenses granted. C-024-25

In Memoriam

James Desmond Smith

April 6, 1940 — January 4, 2026



James Desmond Smith died peacefully at home on Sunday, January 4, 2026. He was a wonderful father and confidant to his two children, James Desmond (Des) Smith (Jo-Anne

Allard) and Wendy Catherine Smith (William Lumsdon).

Predeceased in 2024 by his wife of twenty-four years, Doreen Morrison. He is remembered with love by Doreen's family, Dane Morrison, Alissa Morrison (Jim Duthie), and Shelley Reville.

Son of Miriam Irene Blackburn and Major-General James Desmond Blaise "Des" Smith. Jamie's early life included following his father's post-war military appointments, living in Ottawa, Kingston, and London, England. Recently, he recounted hanging from the balcony of Canada House watching Queen Elizabeth roll past in her carriage on Coronation Day.

Jamie had a lifelong passion for sailing. While living in Montreal, the family boat Wind Wagon was moored at the Royal St. Lawrence Yacht Club. Jamie either raced his own boat or crewed for others. An opportunity to crew on a Dragon brought him to the Duke of Edinburgh's International Dragon Trophy Series hosted at Britannia Yacht Club in Ottawa in July 1967. In attendance was a fellow visiting sailor, HRH Prince Philip himself, and by luck, Jamie found himself included in a post-race audience of 10 sailors with the Prince.

Following his interest in antique and classic boats, Jamie served on the Board of the Antique and Classic Boat Society, Toronto Chapter, from 2003-2009 and was President from 2006-2007. He also served on the ACBS International Board. In 2013, Jamie was inducted into the ACBS Honor Roll in support of classic boating.

Jamie was directly involved as the lead fundraiser of Grace and Speed, the Muskoka Boat and Heritage Centre. Opening its doors

in Gravenhurst in 2006 as Canada's largest in-water collection of classic wooden boats, it has now become the Muskoka Discovery Centre, the home of regional culture and boating history. At the same time, he was heavily involved in the restoration project of Miss Canada IV, an iconic piece of Canadian powerboat history representing Canada's early attempts to dominate world speedboat racing.

Jamie is the Past Director and Founding member of the Florida Vintage Raceboat Club in Tavares, Florida. He and Doreen spent many winters in Mt. Dora, Florida, where Jamie enjoyed 'Peanuts' with the guys and connecting with other vintage boating enthusiasts.

Together with his friend Murray Walker, Jamie co-founded the Canadian Raceboat Hall of Fame in Bracebridge, Ontario.

Opening in 2024, it was a passion project to preserve the history of speedboat racing in Canada. What started out as a small idea to keep the stories of racing past alive is becoming a national storehouse of history as well as a showcase for the future of sport boat racing.

On March 20, 2025, in recognition of his service to Canada and impact on the community, Jamie was awarded the King Charles III Coronation Medal.

A celebration of Jamie's life will be planned for family and friends in the spring.

Should you wish to honor Jamie's life, donations may be made to:

Canadian Raceboat Hall of Fame
www.canadianraceboats.com

Canadian Heart and Stroke Foundation
www.heartandstroke.ca

Aluminum Boat Cradles
INCORPORATED

Baby Your Boat....Put it in a Cradle!
www.boatcradles.com

352-669-3355

Sheerline Magazine



Every organization needs a way to communicate with its members and Sunnyland is fortunate to have people who can put together a great magazine about antique and classic boats for the benefit of our members.

The *Sheerline Magazine* is written, photographed and edited by members and then professionally laid out and printed. It's supported by our advertisers and membership dues.

ADVERTISE YOUR SHOP OR SERVICE

Would you like to support *Sheerline Magazine* and reach 500+ fellow Sunnyland members with your advertising message - contact Don Taylor at 630-632-9797 or email Don at drtaylor@me.com.

The *Sheerline Magazine*, published 4 times a year, is a privilege of Sunnyland membership.

SHARE YOUR STORY

If you have a great idea for a story contact Editor Jeff Funk at 260-414-0016 / email funkfamjj@gmail.com or Assistant Editor Trudi Miklos at 724-312-3993 / email tmiklos4@yahoo.com.

IT'S EASY TO JOIN

Aren't a member of the Sunnyland Chapter of ACBS, it's easy to join. Simply fill out and mail the Membership application form on page 9 of this issue of *Sheerline Magazine*.

Thank You

to the Sponsors and Advertisers who support our Sunnyland Chapter



| | | | |
|---|-------------------|---------------------------------|--------------------|
| Aluminum Boat Cradles..... | 33 | Party Plus..... | 35 |
| Classic Boat Collective..... | 18 | Puddle Jumpers..... | 5 |
| Don Wilson Restorations..... | 35 | Sea Tow..... | 32 |
| Freedom Boat Service..... | 25 | Spacecoast Plating..... | 35 |
| Hagerty..... | 4 | Touchless Boat Cover..... | Inside Front Cover |
| Katz's Marina..... | Inside Back Cover | Truck Tops and More..... | 35 |
| Lancer Craft..... | Back Cover | Victory Engraving & Awards..... | 35 |
| O'Keefe's Irish Pub and Restaurant..... | 35 | Woody Boater..... | 23 |
| Old Time Boat Co..... | 35 | | |

O'KEEFE'S

Irish Pub & Restaurant

Located in the
Downtown Tavares Waterfront
Entertainment District
115 S. Rockingham Ave.



Lunch & Dinner Daily
facebook: OKeefesIrishPub
www.okeefesirishpub.net
Andrew O'Keefe

352-343-2157
Tavares Florida

Gary Scherb

Ingrid Scherb

Doug Scherb



Shop: (352) 742-0475
Cell: (352) 267-5771

28206 CR 561
Tavares, FL 32778

Engines and Accessories Rebuilt



Don Wilson
Keeping Legends Alive

33212 Manatee Rd, Tavares, FL 32778
250 Alsace Ave, Venice, FL 34293
201-835-2616 bluskydw@gmail.com

SPACECOAST PLATING

& Metal Refinishing, Inc.
975 Aurora Road
Melbourne, FL 32935
PH: 321-254-2880 • FAX: 321-254-9115
www.spacecoast-plating.com

David Pratt

Stainless steel and metal polishing.
copper, nickel & chrome plating of marine,
motorcycle & automotive parts



Serving Central Florida for over 20 years.

Your best stop for everything to rent! **352-357-9242**



Please contact us to create your perfect outdoor party, wedding, gatherings and other entertainment functions. Our dedicated professionals will work to fill your needs.

4800 Highway 19 A
Mount Dora, FL 32757
www.grandrent.com



WE'VE GOT YOU COVERED!



Randy Mohr
randy@trucktopsmore.com
352-508-5682 Phone
352-508-5684 Fax

11309 U.S. Highway 441
Tavares, FL 32778
trucktopsmore.com



352.343.8886
VICTORYENGRAVINGFL.COM

WE MAKE CUSTOM:
-SIGNS FOR ELECTRICAL,
CONTROL & INSTRUMENT PANELS
-AWARDS & NAME BADGES -

Trading Dock



**A Sunnyland Members
FREE service.**

**Trading Dock due dates are
January 15, April 15, July 15,
October 15**

NEW LISTINGS: Include a short description of your item, photo (jpeg), your name, address, email address and telephone number. Let us know when your item is sold so we can remove the listing.

RENEWALS: If you want to renew your listing, email Don Taylor on or before the issue due date to keep your ad in the Trading Dock.

**Trading Dock listings must
be renewed each issue.**

**Send your Ad or Renewal
Information to:**

Don Taylor (630) 632-9797
drtaylor@me.com



1956 ARISTOCRAFT powered by a Mercury Mark 58. Vintage trailer. Completely restored and ready for show or go. Price reduced to \$11,000 or best offer. May consider trade. Call or text Bill at (321) 299-2452.



BOAT FUEL

Tavares Boat Slips have fuel for our boats. Open 9am to 5pm daily. They do not take American Express. City of Tavares TAVARES.org

1946 17' DELUXE

RUNABOUT completely restored mostly with new wood. Engine is Hercules 6 cyl KFK also completely rebuilt. Boat has just been refinished with 12 coats of Varnish and is in turn Key Condition. All chrome is replated, all new wiring, gauges rebuilt, new exhaust system. Bottom is west system with fiberglass. All new upholstery. I have had this boat over 30 years and have done a lot of the work myself. Must see in person to appreciate. Single axle trailer included as well as flags, flag poles and some spare parts. Asking \$35000 Contact Nick Cioffi 561-310-6252 or quikwheels@gmail.com



PRE-WAR, 1940 25 FOOT CHRIS CRAFT SPORTSMAN.

HULL# 12507. One of 25 produced between 1940-41. One of 8 known to exist today. Newer cold molded bottom (no soak), 5200 with recent paint. Newer framing/wood from waterline down. Modern power with MerCruiser V8(454) 330 engine. New 30-gal gas tank, prop shaft, wiring, etc.

Big MerCruiser runs great and pushes big woody boat with ease.

New Continental tandem-axle trailer aluminum trailer, with <50 miles on it. Package comes with some extra hardware and dual horns. User boat sailing most weekends in fresh water. Not a museum piece. Could use some new varnishing. 50K for the boat/trailer...OBO Edgar Anders, email: eanders@edgeingredients.com, Phone / WhatsApp: +1 352.408.3051



BOATS FOR SALE

LOCATED IN CONNECTICUT:

1937 Chris Craft 17' Deluxe - Needs restoration. Comes with a restored instrument panel. \$3,000.00

1941 Chris Craft 22' U-22 Deluxe - Easy restoration. Complete hardware, all instruments except tachometer. Has a Chevy V-8 installed. \$8,000.00

1942 Chris Craft 17' Special Runabout - Boat is in good condition, but bottom is weak. \$5,000.00

1950 Chris Craft 22' U-22 - Boat needs to be completed. \$6,000.00

1950 Greavette 18' Dispro - Boat and motor restored. Has won several first place awards and a People's Choice Award. Age forces sale. Price reduced to \$12,500.

1950 Penn Yan 14' Aristocrat - Complete outboard boat. \$800.00

1955 Feathercraft 14' Vagabond - Hull was painted, stripping not completed. Comes with a 50 HP Mercury 500. \$2,000.00

1962 Century 15' Palvo - Restoration started, hardware is rechromed, excellent engine and new old-stock Volvo Penta outdrive. Interior has been redone. \$3,000.00

1971 Thompson 18' Outboard Bowrider - Fiberglass Low hour 115 HP Mariner outboard, plastic fuel tanks, mooring cover, good bimini, perfect original interior, on a good trailer, fresh water use only, runs perfectly, all instruments work. There are no surprises. \$4,000.00

LOCATED IN VERMONT:

1939 14' Larson Outboard Runabout - Available: Evinrude Big 4-33 HP. \$2,000.00

1956 Penn Yan 14' Captivator - Easy restoration of very complete boat including hardware. Available: 35 HP Johnson Electric Start. \$3,000.00

Contact Wes at 352-217-0292.

Leave a message or send a text. All boats are on some sort of trailer, but they are probably not roadworthy. All boats are stored under cover inside.



UP FOR SALE IS THIS BEAUTIFUL 1959 BOWMAN with its original 1959 Mercury Mark 58A and 1959 Tidewater trailer. The 1959 14' Bowman is a very rare seafoam green color boat with beautiful rear fins. The boat has been fully restored with a new transom, flooring, upholstery and the original hardware has been re chromed. The boat comes with all new wiring, bilge pump full waterline Sunbrella cover and removable Sunbrella bimini top.

The 1959 Mark 58A, 45hp with its vintage fuel tank have been fully restored to their original specifications by Alan Spaeth and the engine has less than 20 hours on it. This boat and engine are museum quality and a real eye catcher wherever you take them. The Tidewater trailer has been fully restored with all new wiring, LED lighting, winch and a new dolly wheel. The trailer has new bearings, tires and wheels. The price for this rare piece of history is \$12,500. Contact Pete at 863-412-8816 or capri@tampabay.rr.com



1962 CHRIS CRAFT 25 FOOT SEA SKIFF. \$8500. In good condition. Bottom frames have been sistered and bottom seams cleaned, and treated with smiths and sealed with Boat Life. Proceeds benefit SCAMPY Programor text Bill at (321) 299-2452.

COLLECTOR SELLING FEATHERCRAFTS:

1948 Meteor Prototype, 1953 Vagabond, 1957 Rocket. Various conditions. Email for information, Subject line: Feathercraft to deupreemm@yahoo.com



REBUILT 750 HOLLEY CARBURETOR

DON TAYLOR. Leesburg, FL. \$200
drtaylor@me.com.
630-632-9797

30 GAL. FUEL CADDY. \$150.00

DON TAYLOR. Leesburg, FL.
drtaylor@me.com
630-632-9797



NOVA 24 V-DRIVE 1970

Allan Brown boat. Twin stroker 351w. Stringers/transom/awlgrip/etc. approximately 50 hours. Ready. Probably best out there. Professionally completed in '19. Owned since about 1994. It sat in storage waiting on boathouse until 2021. Located Central Florida. Half of my cost. \$49,900.

Call Craig at 713-446-1555
Email rancherox@yahoo.com



Calendar



February 21, 2026

**Annual Cruise and BBQ
along with Wine Tasting**

Hickory Point Recreation Park

Contact Tom Drozd at 312-907-5779 or

Debi Weinert at 352-609-5134

*See information and application in this issue of
Sheerline.*

February 22, 2026

Quarterly Board of Directors Meeting

1pm | SCAMPY office at Triangle Warehouse

31129 Industry Drive, Tavares, FL 32778

Just west of Bay Road traffic light on Old 441

March 23-26, 2026

**St. John's River Pre-Boat Show Cruise,
Southbound**

Contact Kelly Daniel, 770-490-5989

March 26-29, 2026

45th Annual Sunnyland Boat Festival

Tavares, FL | Contact: Terry Fiest, 407-351-

3424 or Howard Wanamaker, 757-339-0120

March 29 - April 2, 2026

**St. John's River Post-Boat Show Cruise,
Northbound**

Contact: John Heiderich, 317-417-3874

April 17-18, 2026

**Wheels & Keels of Vero Beach
Boat and Car Show**

Moorings Yacht and Country Club

<http://www.wkvero.com> to register

Nov. 6-7-8, 2026

**Sunnyland Annual Dinner and BOD
Meeting in Mt. Dora**

Friday, Nov. 6 - Mt. Dora Yacht Club; dock
boats at the club. Cocktails, heavy hors
d'oeuvres 6-9pm

Saturday, Nov. 7 -

8am - Continental Breakfast

9am - Captains' Meeting on the docks at the
Mt. Dora Yacht Club and begin cruise

6pm - Cocktails and dinner at the Mt. Dora
Yacht Club

Sunday, Nov. 8 - Annual Business

Meeting at the Lakeside Inn

8am - Continental breakfast

9am-noon - Annual Business Meeting

Frank Miklos, Chairman,
Events and Activities Committee

*See acbs-sunnyland.org for more information on
events. Some forms are required for attendance and
are provided on the website.*

RESTORING BOATS, PRESERVING MEMORIES.

As the only antique boat dealer with a one-year warranty on boat sales, we do everything we can to keep the simple way of life afloat. That includes preventive maintenance, refinishing services and repairs, should you need them. We also carry a large assortment of parts and accessories for antique and classic boats. And with over 100 Chris-Craft, Gar Wood, Century and Higgins boats in stock, we're the number one antique boat dealer in the world. Katz's Marina. Proud Sponsors of The Sunnyland Chapter of the ACBS.



AntiqueBoatSales.com
973.663.3214



Photo - Reg Down

The Sheerline
Sunnyland Chapter ACBS
P.O. Box 689
Mount Dora, FL 32756



Lancer Craft

Tradition Meets Innovation

**Lancer Craft debuts Hull No. 1, raising over
\$165,000 for American Cancer Society**

Barnett-Jackson®

NEVADA

THE WORLD'S GREATEST COLLECTOR CAR AUCTIONS®



Lancer Craft



LANCERCRAFT.COM

352-542-7152

The American Cancer Society does not endorse any product or service.